



# Multi Tasker™

MT105-120 is shown above.

MANUAL PART NUMBER: 400-0362-003

## MT105-120/121

### 8X8/8X4 VGA - MATRIX SWITCHER

### (15 Pin HD IN/OUT)

### FOR MULTI-TASKER™

### USER'S GUIDE

## TABLE OF CONTENTS

	Page
PRECAUTIONS / SAFETY WARNINGS .....	2
GENERAL.....	2
INSTALLATION.....	2
CLEANING.....	2
FCC / CE NOTICE .....	2
ABOUT YOUR MULTI-TASKER™ .....	3
TECHNICAL SPECIFICATIONS.....	3
PRODUCT DESCRIPTION .....	4
MT105-120 FRONT PANEL .....	4
APPLICATION DIAGRAMS.....	5
DIAGRAM 1 - TYPICAL SETUP.....	5
DIAGRAM 2 - MT105-120 INTERNAL VIEW .....	6
DIAGRAM 3 - MT105-121 INTERNAL VIEW .....	7
INSTALLING YOUR MULTI-TASKER™ .....	8
OPERATION .....	8
RS-232 CONTROL .....	8
DESCRIPTION OF COMMANDS.....	8
SUMMARY OF COMMANDS .....	17
MENU MODE.....	18
TROUBLESHOOTING GUIDE .....	22
CARD IS NOT RECOGNIZED .....	22
NO DISPLAY .....	22
ALTINEX POLICY .....	22
LIMITED WARRANTY/RETURN POLICY.....	22
CONTACT INFORMATION .....	22

## PRECAUTIONS / SAFETY WARNINGS 1

Please read this manual carefully before using your **MT105-120/121**. Keep this manual handy for future reference. These safety instructions are to ensure the long life of your **MT105-120/121** and to prevent fire and shock hazard. Please read them carefully and heed all warnings.

### 1.1 GENERAL

- Qualified ALTINEX service personnel, or their authorized representatives must perform all service.

### 1.2 INSTALLATION

- To prevent fire or shock, do not expose this unit to rain or moisture. Do not place the **MT105-120/121** in direct sunlight, near heaters or heat radiating appliances, or near any liquid. Exposure to direct sunlight, smoke, or steam can harm internal components.
- Handle the **MT105-120/121** carefully. Dropping or jarring can damage the card.
- Do not pull the cables that are attached to the **MT105-120/121**.
- Insert the card carefully into the slots of the Multi-Tasker™ without bending any edges.

### 1.3 CLEANING

- Clean only the connector area with a dry cloth. Never use strong detergents or solvents, such as alcohol or thinner. Do not use a wet cloth or water to clean the card. Do not clean or touch any component or PCB.

### 1.4 FCC / CE NOTICE

- This device complies with part 15 of the FCC Rules. Operation is subject to the following two conditions: (1) This device may not cause harmful interference, and (2) this device must accept any interference received, including interference that may cause undesired operation.

- This equipment has been tested and found to comply with the limits for a Class A digital device, pursuant to Part 15 of the FCC Rules. These limits are designed to provide reasonable protection against harmful interference when the equipment is operated in a commercial environment. This equipment generates, uses, and can radiate radio frequency energy and, if not installed and used in accordance with the instruction manual, may cause harmful interference to radio communications. Operation of this equipment in a residential area is likely to cause harmful interference in which case the user will be required to correct the interference at his own expense.
- Any changes or modifications to the unit not expressly approved by ALTINEX, Inc. could void the user's authority to operate the equipment.

## ABOUT YOUR MULTI-TASKER™ 2

### MT105-120/121 Re-Configurable VGA-QXGA Video Matrix Switcher Cards

The **MT105-120/121** are VGA-UXGA Video Matrix Switcher Cards designed to switch 150 MHz high bandwidth RGBHV video signals. The **MT105-120** card has eight fixed inputs and eight fixed outputs with 15-pin HD connectors. The **MT105-121** card has eight fixed inputs and four fixed outputs, also with 15-pin HD connectors.

Both cards provide signal detection on input and output through horizontal SYNC. This feature allows for easy remote diagnostics throughout RS-232 commands, from the source all the way to the output connectors.

The **MT105-120/121** provides an economical application due to the space saving design by using D-connectors instead of BNC connectors.

Inputs are switched to outputs through easy-to-use ASCII commands from a control system or computer connected to the RS-232 port of the Multi-Tasker enclosure. Both cards allow muting audio output through RS-232 commands. Inputs and outputs may be programmed in batches and switched all at the same time with a single command.

Used in combination with MT110-100 and MT110-101 Audio Matrix Switcher cards, it is possible to group audio and video inputs and outputs to be switched as audio and video or independently.

A special feature of the **MT105-120/121** is Sync Delay to eliminate the appearance of video signals before the display device is able to process the sync signals and properly format the video image. The Sync Delay is the amount of time to wait after switching the Horizontal and Vertical Sync signals and before switching the RGB signals. Each output may be programmed with a delay ranging from zero to 24.75 seconds, in increments of 250mS.

## TECHNICAL SPECIFICATIONS 3

FEATURES/DESCRIPTION	MT105-120/121
<b>GENERAL</b>	
<b>Inputs</b>	8
Input Connectors	15 PIN HD Female
Internal I/O Con	None
<b>Outputs</b>	MT105-120 = 8 MT105-121 = 4
P&P compatible	YES all inputs
Output Connector	15 PIN HD Female
<b>Compatibility</b>	
Signal type	RGBHV, RGBS, RGsB, Component Video
Signal resolution	VGA through UXGA

Table 1. **MT105-120/121** General

MECHANICAL	MT105-120/121
Enclosure Slots Required	MT105-120 = 4 MT105-121 = 3
Weight	1.1 lb (0.5 kg)
Connector Panel	Black Anodized
T° Operating	10°C-50°C
T° Maximum	75°C
Humidity	90% non-condensing
MTBF (calc.)	50,000 hrs

Table 2. **MT105-120/121** Mechanical

ELECTRICAL	MT105-120/121
<b>Video Input Signals</b>	R,G,B
Impedance Analog	75 Ohms
Analog Signal Level	1.5V p-p max.
<b>Sync Input Signals</b>	H,V
Impedance	10 kOhm
Signal Level	3 - 5 Volts TTL
<b>Output Video Signals</b>	
Impedance Analog	75 Ohms
Gain	1.05
Bandwidth	150 MHz @ -3dB
<b>Output Sync Signals</b>	
Impedance	75 Ohms
Signal Level	4.5 Volts TTL

Table 3. **MT105-120/121** Electrical

## PRODUCT DESCRIPTION

4

### MT105-120 Front Panel

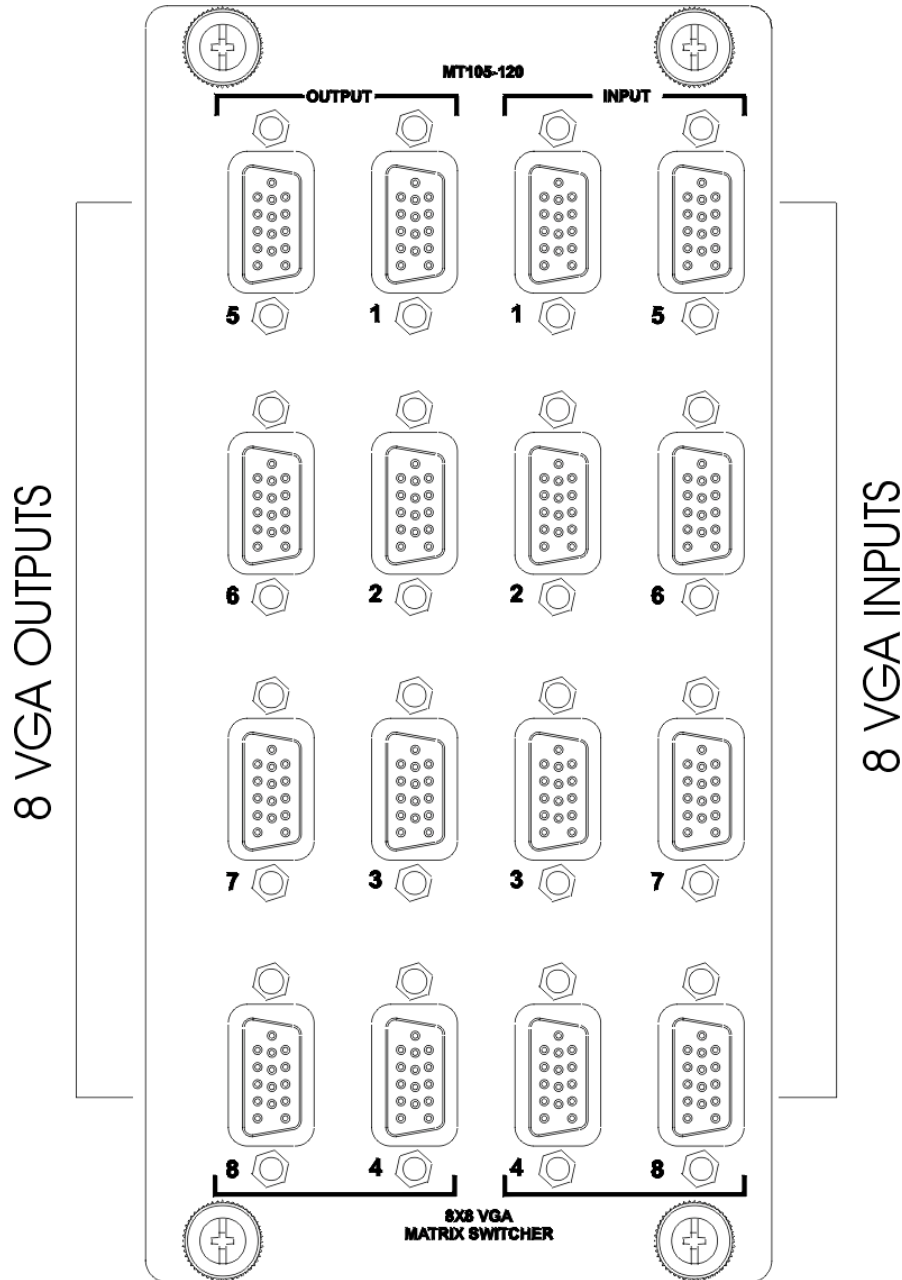

## APPLICATION DIAGRAMS

5

### DIAGRAM 1 - TYPICAL SETUP

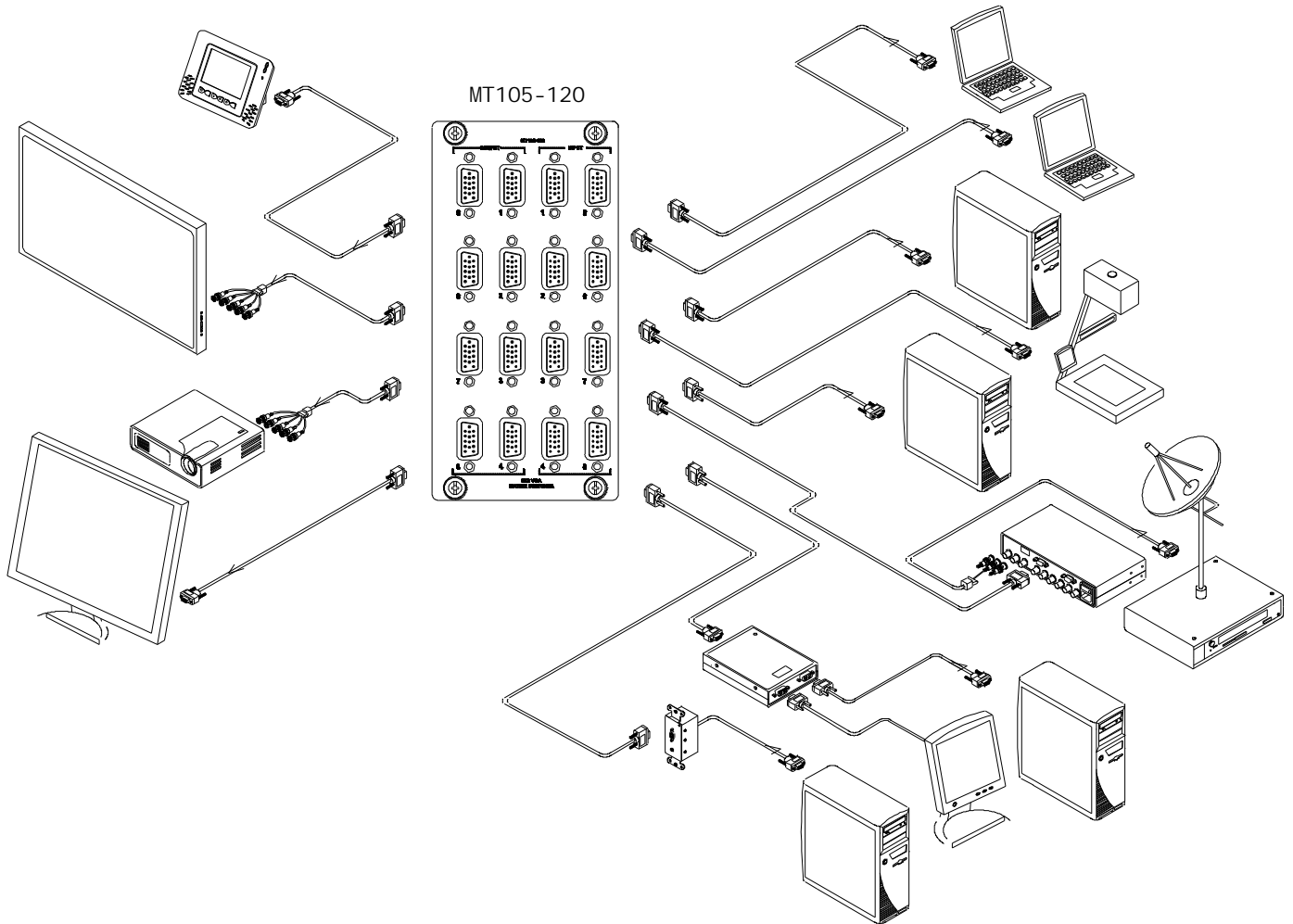

**DIAGRAM 2 - MT105-120 INTERNAL VIEW**

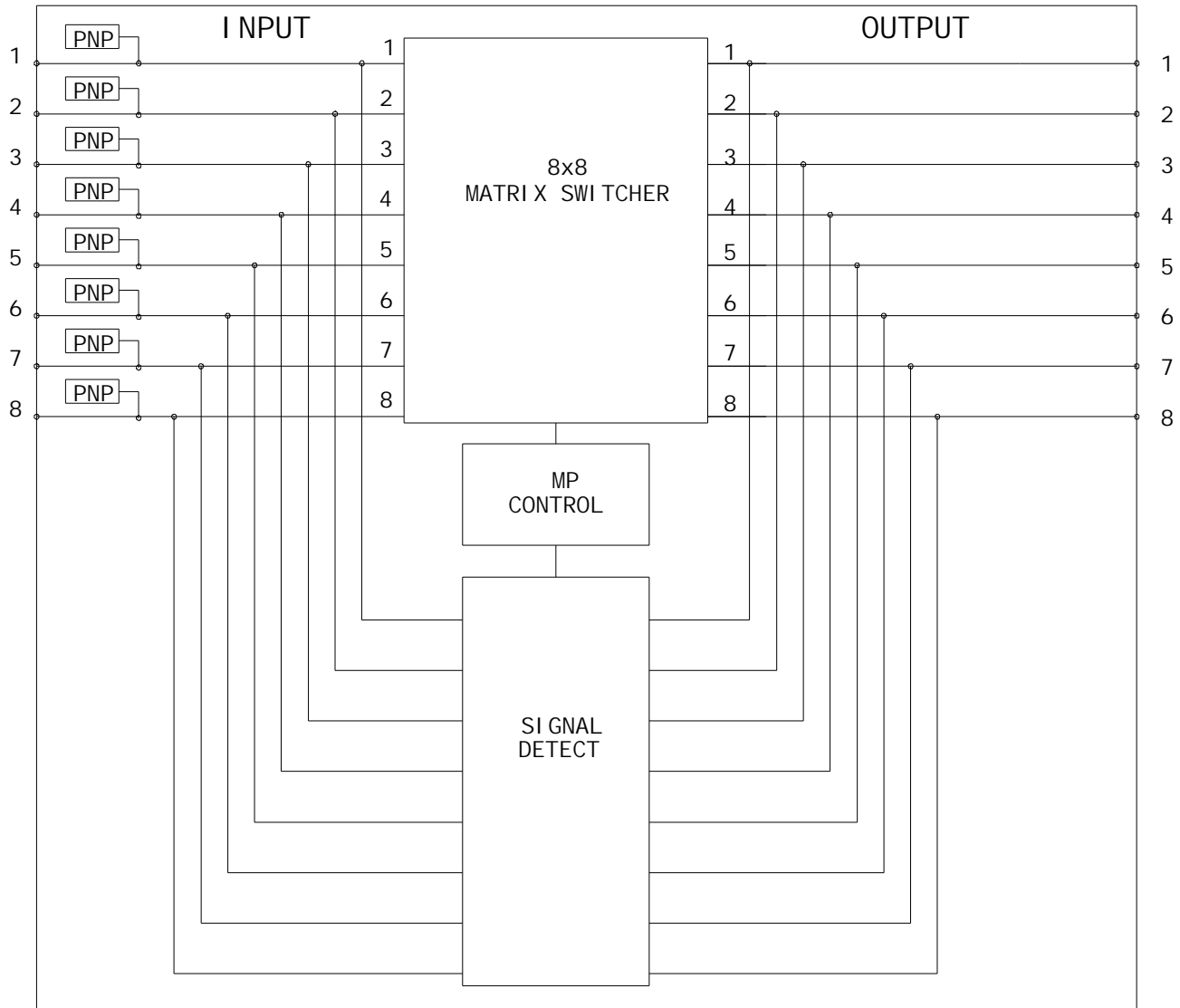

**DIAGRAM 3 - MT105-121 INTERNAL VIEW**

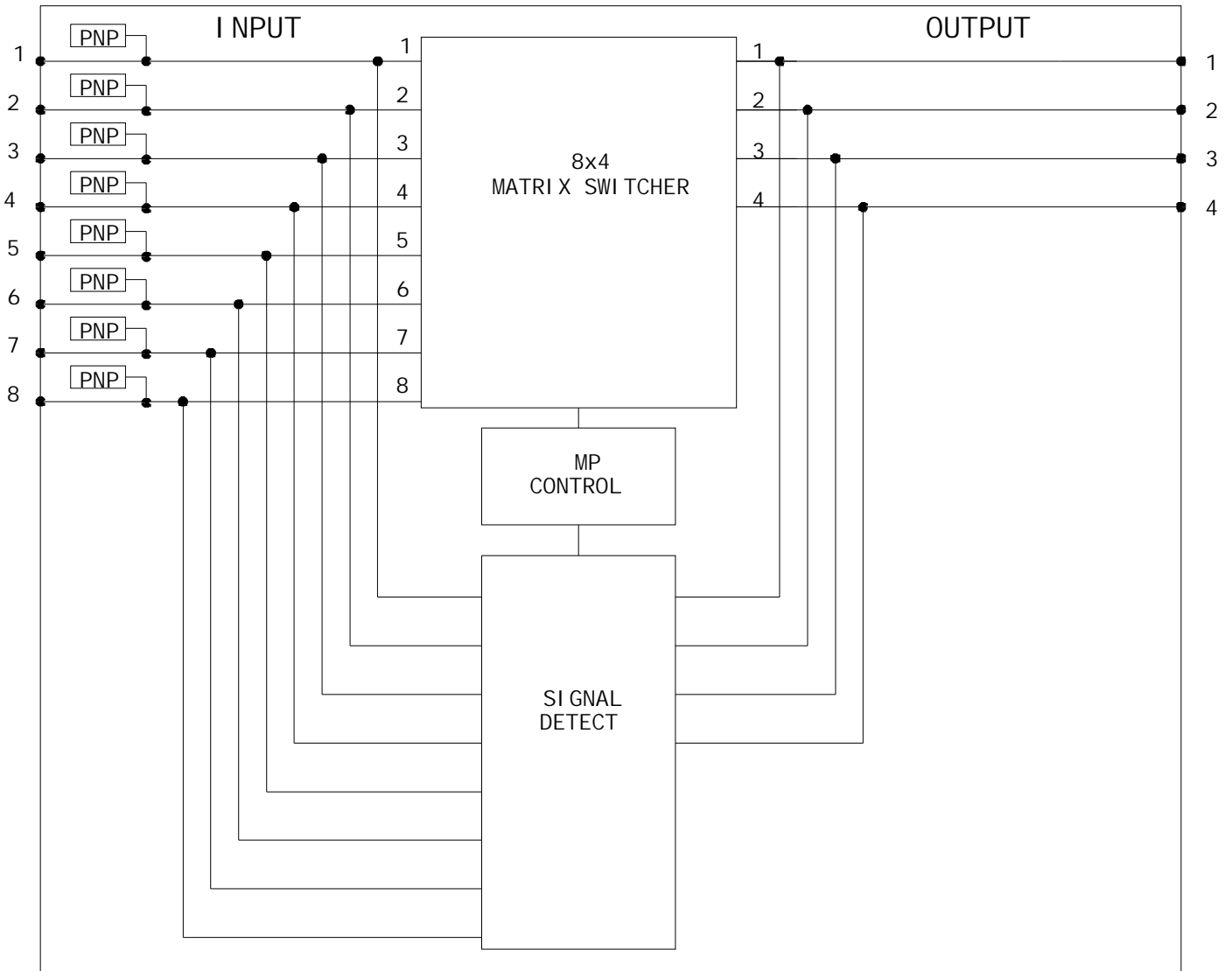



## INSTALLING YOUR MULTI-TASKER™ 6

- Step 1.** Slide the **MT105-120/121** into an available slot in the Multi-Tasker™ Enclosure in order to connect to the bus. Make sure that the **MT105-120/121** card fits into place.
- Step 2.** Secure the card to the Multi-Tasker™ by tightening the retainer screws located on the top and bottom of the **MT105-120/121**.
- Step 3.** Connect a VGA cable from the video source to the input connector of the **MT105-120/121**.
- Step 4.** Connect the output connectors of the **MT105-120/121** to the display devices through a VGA cable.
- Step 5.** Starting from the left, identify the slot number where the **MT105-120/121** card is plugged into the Enclosure and note that it is for RS-232 control.

## OPERATION 7

### 7.1 RS-232 CONTROL

When used in the Multi-Tasker™ Enclosure, the **MT105-120/121** has many advanced remote control capabilities, which are accessible through standard RS-232 communication. The actual controlling can be accomplished through a computer control system or any other device capable of sending RS-232 commands.

#### 7.1.1 RS-232 INTERFACE

The RS-232 commands, for the **MT105-120/121**, are in a simple ASCII character format.

1. Square brackets “[ ]” are part of the command.
2. Use uppercase letters for all commands.

After processing a command, an OK or ER will be returned as feedback if "F" is included at the end of a command string.

Commands ending in "S" will be saved into memory. Commands not ending in "S" will still be executed but will not be restored when the system is reset or powered OFF then ON.

### 7.2 DESCRIPTION OF COMMANDS

Each command consists of three parts: Function, Card ID, and Unit ID.

[ Function , Card ID , Unit ID ]

Example: [VERC3U2]

VER= Function

C3 = Card ID or Group ID

U2 = Unit ID

For Function, see a detailed explanation under each command description.

The Card ID is an assigned value. It is equal to the enclosure slot number in which the card is installed. The value can range from 1 to 4 up to 1 to 20 depending on the enclosure.

Card ID 0 (C0) is used for the controller. See the MT100-100 User's Guide for details.

The Group ID is a number representing a group of cards defined with the [WR] command. When using the Group ID, all cards in the group will perform the given instruction.

Changing the position of a card will significantly affect the commands recorded on software definitions or third party control systems.

The Unit ID has a value from 0 to 9. Unit ID 0 should be used for single unit operation. If the Unit ID is set to zero, each command may be used without Ui. Use the command [SETU0], as explained in the MT100-100 User's Guide.

Example:

[VERC3]: For Unit ID Zero

[VERC3Ui]: For Unit ID other than Zero

[VERC3]: Equivalent to [VERC3U0]

## 1. [VER]

This command displays the software version and card type for the **MT105-120/121** card.

Command Format: [VERCnUi]

Cn = Card ID (n = slot # from 1 to max slots)

Ui = Unit ID (i = # from 0 to 9)

Example:

An **MT105-120** card is in slot #4. Send the command [VERC4], and the Multi-Tasker™ Enclosure will return the following feedback:

MT105-120 690-0170-003

MT105-120 = the card model

690-0170-003 = the software version

## 2. [C]

This command displays the status of the card and connections of the Matrix Switcher.

Command Format: [CnUi]

Cn = Card ID (n = slot # from 1 to max slots)

Ui = Unit ID (i = # from 0 to 9)

Example:

An **MT105-120** card is in slot #4. Outputs 1, 2 and 3 are ON. Input 1 is connected to Output 1. Input 2 is connected to all the remaining outputs.

Sending the command [C4] will yield the following feedback:

Matrix:8X8

In1-Out1 ON

In2-Out2 ON

In2-Out3 ON

In2-Out4 OFF

In2-Out5 OFF

In2-Out6 OFF

In2-Out7 OFF

In2-Out8 OFF

If there is no card in slot #4, sending the [C4] command will not return any feedback.

## 3. [CnS]

This command saves the input to output settings, as well as, the ON/OFF status of each output. This configuration will be restored after the system is reset or powered off then on.

Cn = Card ID (n = slot # from 1 to max slots)

Ui = Unit ID (i = # from 0 to 9)

Example:

There is an **MT105-120** in slot #4. Input 1 is connected to all outputs, but only outputs 1 through 3 are ON. The feedback after sending the command [C4S] would be:

Matrix:8X8

In1-Out1 ON

In1-Out2 ON

In1-Out3 ON

In1-Out4 OFF

In1-Out5 OFF

In1-Out6 OFF

In1-Out7 OFF

In1-Out8 OFF

Saved

## 4. [?CnUi]

This command will return general information about the card and its status. It is a function of both the card and the front panel and is only available with Multi-Tasker™ Front Panel systems that have the following firmware:

690-0122-015 = Version 015 or later.

690-0123-004 = Version 004 or later.

690-0124-018 = Version 018 or later.

NOTE: In MTSetup™, send the command [VER] from the Terminal Window. The system will respond with feedback similar to the following:

[690-0122-015 690-0123-004 690-0124-018]

Check the last three digits against the numbers above to determine if the MENU MODE option is available.

Command Format: [?CnUi]

Cn = Card ID (n = # from 1 to max slots)

Ui = Unit ID (i = from 0 to 9)

Example:

The **MT105-120** in slot #4 has Input 1 connected to all outputs and all outputs turned ON. Send the command [?C4] to receive the feedback status.

Each status field begins with a '+' and ends with the card slot number (ex: C04). The feedback will be similar to the following:

```
[+MT105-120C04+VR690-0170-003C04  
+ON11111111C04+MA0101010101010101C04  
+SI10000000C04+SO11111111C04]
```

MT105-120	= Card Type
VR690-0170-003	= Firmware version
ON11111111	= Output ON/OFF status
MA01010101010101	= Matrix I/O connections
SI10000000	= Input Signal Detect
SO11111111	= Output Signal Detect

The ON/OFF line is read from left to right, outputs one through eight. A "1" indicates the output is ON, a "0" indicates the output is OFF.

The I/O connections are also read left to right representing outputs one through eight and the input to which each is connected. The first two digits are the input to which Out 1 is connected.

The Signal Detects read left to right in increasing order as well. The Input Signal Detect shows Input 1 has an active signal at the input, but inputs 2 thru 7 do not. The Output Signal Detect shows all 1's indicating there is an output signal present on all the output connectors since Input 1 is connected to all outputs and the outputs are enabled.

## 5. [STA]

This command enables and disables automatic feedback from the front panel. The command affects any card with auto-feedback capability, not just the **MT105-120/121**. The default at power on or reset is STA0, OFF.

Command Format [STA1] = ON  
Command Format [STA0] = OFF

Feedback Prefix Definitions:

+VR	= Firmware Version
+MA	= Matrix Connections
+ON	= Output ON/OFF Status
+SI	= Input Signal Detect
+SO	= Output Signal Detect

Example 1:

```
Command = [I1O1C4]  
Feedback = [+MA0103010101010101C04]  
          +MA           = Matrix  
          01030101010101 = Output Connections  
          C04           = Card slot number
```

Reading from left to right, the first two digits represent the input number connected to Output 1. In this case, Input 1 to Output 1. The next two digits are for Output 2. In this case, Output 2 is connected to Input 3. The remaining Outputs are all connected to Input 1.

Example 2:

```
Command = [ON1C4]  
Feedback = [+ON1000000C04]  
          +ON      = Output Status  
          1000000 = Outputs ON and OFF  
          C04     = Card slot number
```

Reading from left to right, the first digit represents the status of Output 1. A "1" indicates ON and a "0" indicates OFF. In this case, Output 1 is ON and the remaining Outputs, 2-8, are OFF.

## 6. [SDL]

This command displays the Sync Delay programmed for each output.

Command Format: [SDLCnUi]

Cn = Card ID (n = # from 1 to max slots)

Ui = Unit ID (i = from 0 to 9)

Example:

There is an **MT105-120** in slot #4. Send the command [SDLC4] and feedback similar to the following:

SYNC DELAY FOR OUTPUT 1 THROUGH 8  
(SDL1 to SDL8):

SDL1=01 (00.25 Sec)

SDL2=03 (00.75 Sec)

SDL3=04 (01.00 Sec)

SDL4=10 (02.50 Sec)

SDL5=20 (05.00 Sec)

SDL6=00 (00.00 Sec)

SDL7=00 (00.00 Sec)

SDL8=00 (00.00 Sec)

## 7. [SDLm=s]

This command sets the Sync Delay for each output. The Sync Delay is the amount of time to wait after switching the Horizontal and Vertical Sync signals to the new output. When switching input to output connections, the RGB signals are disabled first. Then, the RGBHV signals are switched to the new output with the H and V signals enabled. After the delay, the RGB signals are enabled on the new output. Each individual output may be programmed with a Sync Delay ranging from zero to 24.75 seconds, in increments of 250mS.

Command Format: [SDLm=sCnUi]

m = Output (m = # 1 to 8)

s = Sync Multiplier (s = # from 0 to 99)  
Delay = Multiplier X 250mS.

Cn = Card ID (n = # from 1 to max slots)

Ui = Unit ID (i = from 0 to 9)

Example:

There is an **MT105-120** in slot #4. Send the command [SDL1=4C4] to set the Sync Delay for Output 1 to one second.

## 8. [SIGI]

The Signal Present command tests for the presence of an input signal. The Multi-Tasker™ returns either a "1" or a "0" as feedback.

1 = Signal detected

0 = No signal detected

Command Format: [SIGImCnUi]

m = Input (m = # from 1 to 8)

Cn = Card ID (n = # from 1 to max slots)

i = Unit ID (i = # from 0 to 9)

Example:

There is a properly formatted input signal being applied to Input 2 of the card in slot #4. Check for the presence of an input signal by sending the command [SIGI2C4]. The feedback will be a "1" immediately following the command sent:

[SIGI2C4] 1

[SIGI2C4] = command sent

1 = feedback, signal is present

## 9. [SIGO]

The Output Signal Detect command tests for the presence of an output signal on one output. The Multi-Tasker™ returns either a "1" or a "0" as feedback.

1 = Signal detected

0 = No signal detected

Command Format: [SIGOmCnUi]

m = Output (m = # from 1 to max outputs)

Cn = Card ID (n = # from 1 to max slots)

Ui = Unit ID (i = # from 0 to 9)

Example 1:

The card in slot #4 has Input 1 connected to Output 1 and Output 1 is turned ON. Verify the output signal is detected by sending the command [SIGO1C4] and receiving feedback equal to "1".

## 10. [ON]

This command will enable one or more outputs for a single card, or a group of cards.

### SINGLE CARD OPERATION

Command Format: [ONmCnUi]

m = Output (m = # from 1 to max outputs)

Cn = Card ID (n = # from 1 to max slots)

Ui = Unit ID (i = # from 0 to 9)

Example:

There is an **MT105-120** card in slot #5. All of the outputs on the card are OFF.

- 1) [ON1C5]: Turns ON only Output 1 of the MT105-120 card.
- 2) [ON12C5]: Turns ON Outputs 1 and 2.
- 3) [ONC5]: Turns ON all Outputs.

### GROUP OPERATION

Command Format: [ONmGkUi]

This command enables Output "m" for each card in group "k" of unit "i".

m = Output (m = # from 1 to max outputs)

Gk = Group number (k = # from 1-8)

Ui = Unit ID (i = # from 0-9)

Example:

[ON1G1]: Turns ON Output 1 for each card in Group 1. See the GROUP commands for a detailed explanation.

### PATH OPERATION

This command will set the path for the output, but it is not active until the switch command, [SW], is executed. Commands ending in "P" are not executed immediately. The path for outputs on multiple cards or the same card may be preloaded.

Command Format: [ONmCnUiP]

m = Output (m = # from 1 to max outputs)

Cn = Card ID (n = slot # from 1 to max slots)

Ui = Unit ID (i = # from 0 to 9)

P = Path

Example:

There are two **MT105-120** cards in slots 6 and 7. Enable Output 1 of card 6 and Output 3 of card 7 simultaneously. To do this, send the following commands:

[ON1C6P]

[ON3C7P]

[SW]

If "F" is included, use the [ONmCnPF] command or the [ONmCnFP] command.

### FEEDBACK OPERATION

After processing a command, an OK or ER will be returned as feedback if "F" is included at the end of a command string.

Command Format: [ON.....F]

Example:

[ON1C2F]: if path is not set

[ON1C2PF]: if path is set

## 11. [OFF]

This command disables one or more outputs for a single card or a group of cards.

### SINGLE CARD OPERATION

Command Format: [OFFmCnUi]

m = Output (m = # from 1 to max outputs)

Cn = Card ID (n = # from 1 to max slots)

Ui = Unit ID (i = # from 0 to 9)

Example:

Card 5 has Output 1 ON. The following commands may be used to turn OFF the output.

- 1) [OFF1C5]: Turns OFF Output 1 only.
- 2) [OFF23C5]: Turns OFF Outputs 2 and 3.
- 3) [OFFC5]: Turns OFF all outputs.

### GROUP OPERATION

Command Format: [OFFmGkUi]

This command disables output "m" for each card in group "k" of unit "i".

m = Output (m = # from 1 to max outputs)

Gk = Group ID (k = # from 1-8)

Ui = Unit ID (i = # from 0-9)

Example:

1. [OFF1G1]: Turns OFF Output 1 for each card in group 1.
2. [OFFG1]: Turns OFF all outputs for each card in group 1.

### PATH OPERATION

Command Format: [OFFmCnUiP]

This command will set the path for the output, but it is not active until the switch command, [SW], is executed. Commands ending in "P" are not executed immediately. The path for outputs on multiple cards or the same card may be preloaded.

m = Output (m = # from 1 to max outputs)

Cn = Card ID (n = # from 1 to max slots)

Ui = Unit ID (i = # from 0 to 9)

P = Path

Example:

There are two **MT105-120** cards in slots 6 and 7. Disable Output 1 of card 6 and Output 3 of card 7 simultaneously using the following commands:

```
[OFF1C6P]
[OFF3C7P]
[SW]
```

If "F" is included, use the [OFFmCnP] command or the [OFFmCnFP] command.

### FEEDBACK OPERATION

Command Format: [OFF.....F]

After processing a command, an OK or ER will be returned as feedback if "F" is included at the end of a command string.

Example:

[OFF1C2F]: if path is not set

[OFF1C2PF]: if path is set

## 12. [...S] – SAVE

This command will save the configuration command being sent in memory. When sending the command [I1O1C4S], after reset or power up, Input 1 will be connected to Output 1 on C4. This command only saves the Input 1 to Output 1 connection above. In order to save all the current settings, use the [CnS] command.

## 13. [...F] – FEEDBACK

After processing a command, an OK or ER will be returned as feedback if "F" is included at the end of a command string.

## 14. [...P] – PATH

This command will set the path for the output, but it is not active until the switch command, [SW], is executed. Commands ending in "P" are not executed immediately. The path for outputs on multiple cards or the same card can be preloaded. See the examples in the ON and OFF command descriptions.

Example:

There is an **MT105-120** in slot #4. Currently, Input 1 is connected to all outputs and all outputs are ON. The PATH command has been used to set Input 2 to Output 1 and turn OFF Outputs 2 and 3 at the same time. If checking the status prior to sending the [SW] command, the feedback will appear as follows for the above connection settings:

```
In1-Out1 ON P=2
In1-Out2 ON P=OFF
In1-Out3 ON P=OFF
In1-Out4 ON
In1-Out5 ON
In1-Out6 ON
In1-Out7 ON
```

The notation "P=" at the end of the line indicates the path condition is active. "P=2" on the Output 1 line indicates that after the [SW] command, Input 2 will be connected to Output 1.

The notation "P=OFF" on lines 2 and 3 indicates that Outputs 2 and 3 will be turned OFF after the [SW] command is executed.

## 15. [SW] – SWITCH

This command immediately connects inputs and outputs previously set with the PATH command. The command switches all paths set on this card and all other cards in the enclosure.

Example:

The following commands set the path for turning ON Output 1 of the card in slot #6 and turning OFF Output 3 of the card in slot #7. Nothing happens until the [SW] command is sent. At that time, Output 1 will be enabled and Output 3 will be disabled.

```
[ON1C6P]
[OFF3C7P]
[SW]
```

## 16. [IO]

This command will connect a single input with one or all outputs. It will not effect the ON/OFF status of the output.

Command Format: [IxOyCnUi]

x = Input (x = # from 1 to max inputs)

y = Output (y = # from 1 to max, or [ for all)

Cn = Card ID (n = # from 1 to max slots)

Ui = Unit ID (i = # from 0 to 9)

Example:

An **MT105-120** is in slot #4 Connect Input 1 to all outputs by sending the command [I1O[ C4]. After the command is sent, Input 1 will be connected to all outputs. In order to turn ON all the outputs, send the command [ONC4].

## 17. [CLR]

This command resets the card configuration to the factory defaults. After the [CLR] command, Input 1 will be connected to all outputs and all outputs will be ON.

Command Format: [CLRCnUi]

Cn = Card ID (n = # from 1 to max slots)

Ui = Unit ID (i = # from 0 to 9)

Example:

Send the command [CLRC4] to reset the card in slot #4 to its factory defaults.

## 18. [MATmXnC*i*]

This Matrix command allows the switcher card to be setup for different matrix sizes.

m = number of inputs (8,4,2)

n = number of outputs (8,4,2,1)

i = card number (1-20)

MT105-120 8 X 8		MT105-121 8 X 4	
Input	Output	Input	Output
O5 O1	O1 O5	O5 O1	O1
O6 O2	O2 O6	O6 O2	O2
O7 O3	O3 O7	O7 O3	O3
O8 O4	O4 O8	O8 O4	O4

MT105-120 4 X 4		MT105-121 4 X 2	
Input	Output	Input	Output
O3a O1a	O1a O3a	O3a O1a	O1a
O3b O1b	O1b O3b	O3b O1b	O1b
O4a O2a	O2a O4a	O4a O2a	O2a
O4b O2b	O2b O4b	O4b O2b	O2b

MT105-120 2 X 2		MT105-121 2 X 1	
Input	Output	Input	Output
O2a O1a	O1a O2a	O2a O1a	O1a
O2b O1b	O1b O2b	O2b O1b	O1b
O2c O1c	O1c O2c	O2c O1c	O1c
O2d O1d	O1d O2d	O2d O1d	O1d

## 19. [TEST]

This command performs a test on the internal memory. Upon completion, the system will display the results. If there are no problems, the system will display the following:

MEMORY IS GOOD

Otherwise, failures will be indicated.

Command Format: [TESTCnUi]

Cn = Card ID (n = slot # from 1 to max slots)

Ui = Unit ID (i = # from 0 to 9)

Example:

There is an **MT105-120** in slot #4. Send the command [TESTC4] to test the internal memory.

## 20. [HELP]

This command displays information available for the Multi-Tasker interface commands.

Command Format: [HELPCnUi]

Cn = Card ID (n = # from 1 to max slots)

Ui = Unit ID (i = # from 0 to 9)

Example:

In order to display the RS-232 commands available for the **MT105-120/121** card in slot #2, send the command [HELPC2]. The commands along with a brief description will be displayed in the Terminal Window.

## 21. [WR]

This command groups multiple cards in the enclosure allowing all the group members to be controlled simultaneously with the same command. Each unit may define a maximum of eight groups.

In Multi-Tasker™ systems with audio and video cards, boards are typically grouped as follows:

Group 1 = Video Cards

Group 2 = Audio Cards

Group 3 = Video and Audio Cards

If assigning group commands to button functions, it is best to use the "Press and Hold on Power Up" to make group settings.



Command Format: [WRC<sub>n1</sub>C<sub>n2</sub>...GkUi]

C<sub>n</sub> = Card ID (n = slot # from 1 to max slots)

Gk = Group number (k = # from 1-8)

Ui = Unit ID (i = # from 0-9)

Example:

To group cards 1, 2, and 3 as group 5 of Unit ID 1, send the command [WRC1C2C3G5U1]. After executing this command, cards 1, 2 and 3 will be grouped together as group 5 of Unit ID 1. The system will return the following feedback:

G1=C1C2C3

Now, when a command is sent to G1, each board in G1 will execute the same command.

## 22. [RMC]

This command may be used to remove one or more group members from a group.

Command Format: [RMC<sub>n1</sub>C<sub>n2</sub>...GkUi]

C<sub>n</sub> = Card ID (n= # from 1 to max slots)

Gk = Group number (k = # from 1-8)

Ui = Unit ID (i = # from 0-9)

Example:

Group 1 consists of the cards located in slots numbered 1, 2, 3, 4 and 5. Remove just cards #4 and #5 from the group by sending the command [RMC4C5G1]. The system will return the following feedback:

G1=C1C2C3

## 23. [RMG]

This command may be used to delete an entire group, or all groups.

REMOVE ONE GROUP MEMBERS

Remove all the members from the group, effectively deleting the group.

Command Format: [RMGkUi]

Gk = Group number (k = # from 1-8)

Ui = Unit ID (i = # from 0-9)

Example:

Group 1 consists of the cards located in slots number 1, 2 and 3. Remove all cards from the group by sending the command [RMG1]. The system will return the following feedback:

G1=EMPTY

REMOVE ALL GROUPS

Remove all the members from every group, effectively deleting all groups.

Command Format: [RMG [ Ui]

Ui = Unit ID (i = # from 0-9)

Example:

Group 1 consists of cards 1 and 2. Group 2 consists of cards 1, 2, 3, 4 and 5. Delete all the groups by sending the command [RMG [ ]. The system will return the following feedback:

G1-G8:EMPTY

## 24. [RD]

This command reads and then displays the members in each group.

Command Format: [RDGkUi]

Gk = Group number (k = # from 1-8)

Ui = Unit ID (i = # from 0-9)

Example:

The cards in slots 1, 2 and 19 are part of group 5. Read the member data for group 5, by sending the command [RDG5]. The system will return feedback as follows:

G1=C1C2C19

The feedback shows G1 (Group 1) and then the cards that make up Group 1. In this case, Group 1 includes C1, C2 and C19.

## 25. [CLRG]

This command clears the members for a single group or for all groups. The clear command restores the cards to default settings and is the equivalent to sending the [CLR] command to each individual card.

NOTE: Since this command is sending the [CLR] command to its group members, each card will display its own reset message, if any.

Command Format: [CLRGkUi]

Gk = Group ID (k = # from 1-8, or [ for all)

Ui = Unit ID (i = # from 0-9)

Example:

- 1) To clear group 1 of Unit ID 0, send the [CLRG1] command. This command clears the members for the specified group only.
- 2) To clear all groups of Unit ID 1, send the [CLRG[U1]] command.

## 26. [CLM]

This command removes the members in a group and leaves the group empty. It is equivalent to sending the [RMGkUi] command without card references.

Command Format: [CLMGkUi]

Gk = Group number (k = # from 1-8)

Ui = Unit ID (i = # from 0-9)

Example:

Group 5 of Unit ID 1 contains the cards in slots 1, 2 and 19. Read the member data for group 5 of Unit ID 1. Send the command [RDG5U1] and receive the following feedback:

G1=C1C2C19

Now, clear group 5 by sending the command [CLMG5U1]. Reread the member data as above and note the following feedback:

G1=EMPTY

## 7.3 SUMMARY OF COMMANDS

### Card Commands

- 1) [VER] Receives software version
- 2) [C] Receives status of the card
- 3) [CnS] Save card settings
- 4) [?] Show status/ general information
- 5) [STA] Enable/disable auto feedback
- 6) [SDL] Read Sync Delay settings
- 7) [SDLm] Set Sync Delay settings
- 8) [SIGI] Input signal detect
- 9) [SIGO] Output signal detect
- 10) [ON] Turns on one or more outputs for a single card or a group of cards
- 11) [OFF] Turns off one or more outputs for a single card or a group of cards
- 12) [...S] Save the command configuration
- 13) [...F] Provides feedback upon sending
- 14) [...P] Sets the path, preload for [SW]
- 15) [SW] Switch preloaded output buffer
- 16) [IO] Connects inputs to the outputs
- 17) [CLR] Reset card to default values
- 18) [MAT] Define the matrix size
- 19) [TEST] Test internal memory IC's
- 20) [HELP] Display available commands

### Group Commands

- 21) [WR] Groups multiple cards
- 22) [RMC] Remove members from a group
- 23) [RMG] Remove one or more groups
- 24) [RDG] Displays group members
- 25) [CLRG] Clears group members
- 26) [CLM] Removes an entire group

## 7.4 MENU MODE

MENU MODE commands are RS-232 commands that allow virtually the same functionality as programming commands. Unlike the programming commands in the previous sections, 7.2 and 7.3, MENU commands prompt the user to select from a list of available options. The system then responds based upon selections made by the user.

MENU commands may be issued in response to prompts from within MTSetup™ or other RS-232 communication software.

The MENU driven commands are only available with Multi-Tasker™ Front Panel systems that have the following firmware:

690-0122-015 = Version 015 or later.

690-0123-004 = Version 004 or later.

690-0124-018 = Version 018 or later.

NOTE: In MTSetup™, send the command [VER] from the Terminal Window. The system will respond with feedback similar to the following:

[690-0122-015 690-0123-004 690-0124-018]

Check the last three digits against the numbers above to determine if MENU MODE is available.

### 7.4.1 MENU COMMAND DEFINITIONS

Refer to section 7.2 for details on card functions and examples. Following is a cross-reference of menu mode versus programming commands.

MENU	COMMAND
Control	
Select	n/a
Save	[CnS]
Clear	[CLR], [CLRG]
ON/OFF	[ON], [OFF]
IN/OUT	[IO]
Setup	
Sync Delay	[SDL], [SDLm]
Group	[WR], [RM], [CLM]
Status	[VER], [C]
Help	[HELP]
Not Available	[?], [STA], [...S], [...F], [...P], [SW], [TEST], [RD], [RMG], [CLM] and [RD]

## 7.4.2 USING MENU MODE

SUGGESTION: Before using the menu mode, it is best to disable the automatic feedback feature. The values and current settings will be displayed in the menu mode, but the automatic feature will display after each setting change making the menus difficult to read.

1. In order to run MENU mode, the system must be connected to a computer running MTSetup™ or other RS-232 control software.
2. Insert the card into an empty slot and push in all the way for a secure fit.
3. Reset the system or power the system OFF and then ON.
4. In MTSetup™, click in the Terminal Window then press the ENTER key.
5. The system interrogates the enclosure and returns a list of cards installed and their slot locations.

Example: 4 (Slot 4): **MT105-120**

NOTE: Only cards supporting the MENU feature will be displayed.

5. Find the alphanumeric character representing the card whose setup requires changing. It's the first character in the line.
  6. Press the number or letter associated with the card, and a menu with options available for that card will appear on the screen. In the example above, press "4".
- WARNING: Do NOT enter any characters except the one relating to the desired menu. Pressing ENTER or RETURN after "4" will force the system back to the original prompt.
7. After selecting the **MT105-120** as described above, the system will prompt for selections specific to that card.
  8. Read each menu carefully, and continue selecting keys as prompted for further functions. (Example prompt: "Key= ")

## 7.4.3 MENU TYPES

### 1. MAIN MENU

The first menu displayed after selecting the card is the Main Menu. This menu provides access to the main functions related to the card. Press the key representing the menu item for access. A sub menu will appear next.

### 2. SUB MENU

Each sub menu will display either another menu (sub menu) or a list of available options or settings. Press the key corresponding to the menu choice to change a setting or select the next menu.

NOTE: Pressing the ESCAPE (ESC) key in most menus will take you up to the previous menu without making changes in the current menu. In the some menus, the ESC key is used to confirm the card/group selection or new settings.

## 7.4.4 MT105-120/121 MENUS

Following are the menus available to the **MT105-120/121**. The first menu is the Main Menu only. The second listing is an expansion of all the menu items.

The expanded menu contains values in parentheses that indicate the current setting or value of that parameter. In some areas, additional comments are provided for clarification.

Some menu settings act as toggle features. For example, the ON/OFF command for each output as only one option. If Output 1 is ON, pressing 1 in the ON/OFF menu will turn Output 1 OFF. Pressing it again will turn Output 1 ON again. In short, pressing 1 repeatedly will toggle Output 1 ON and OFF.

System prompts requiring specific values for input numbers or output numbers, card number etc... are not shown. See the examples following the menus for details.

The IN-OUT menu requires the user to input the numeric value of the input to switch, then it will prompt for the output to which the input will be switched. After each change, the system will respond with "ok". Entering "S" will redisplay the connection settings.

The Sync Delay menu will prompt the user to select the output number for delay. After that, the system will display a one line prompt so the user can enter the Sync Delay value.

**CAUTION:** Pay special attention to the top of the CONTROL menu. After selecting the CONTROL menu, THIS CARD or a group number will be identified at the top of the sub menu. Since group functions may be modified from this menu, make sure the desired card or group is selected.

### MT105-120/121 MAIN MENU

PRESS KEY TO SELECT

1: CONTROL

2: SETUP

3: STATUS

4: HELP

ESC: GO BACK

KEY=

### MT105-120/121 EXPANDED MENU

#### 1. CONTROL: THIS CARD

1: SELECT (Card/Group for Control)

CURRENT SELECTION: THIS CARD

0: This Card

1: Group 1

2: Group 2

3: Group 3

4: Group 4

5: Group 5

6: Group 6

7: Group 7

8: Group 8

ESC: GO BACK

KEY=

## 2: SAVE (Card Settings)

In1-Out1 ON  
In1-Out2 ON  
In1-Out3 ON  
In1-Out4 ON  
In1-Out5 ON  
In1-Out6 ON  
In1-Out7 ON

SAVE THIS SETTING?

1: YES

2: NO

KEY=

## 3: CLEAR (Set to Defaults)

RESET CARD TO FACTORY DEFAULT:

\* All Outputs: Connected To Input1

\* All Outputs: Turned On

1: YES

2: NO

KEY=

## 4: ON/OFF (Turn Outputs On/Off)

TOGGLE ON/OFF: ENTER A NUMBER

0: All OFF

1: Out1 (ON)

2: Out2 (ON)

3: Out3 (ON)

4: Out4 (ON)

5: Out5 (ON)

6: Out6 (ON)

7: Out7 (ON)

9: All ON

ESC: GO BACK; S:STATUS

KEY=

## 5: IN-OUT (Switch I/O Connection)

SWITCH IN-OUT: ENTER A NUMBER

In1-Out1 ON

In7-Out2 ON

In1-Out3 ON

In1-Out4 ON

In1-Out5 ON

In1-Out6 ON

In1-Out7 ON

ESC: GO BACK; S:STATUS

In

## 2: SETUP

### 1: SET GROUP ID

CURRENT GROUP ID: NONE

#### 1: ASSIGN GROUP ID

ASSIGN GROUP ID: ENTER NUMBER

1: Group 1

2: Group 2

3: Group 3

4: Group 4

5: Group 5

6: Group 6

7: Group 7

8: Group 8

ESC: GO BACK

KEY=

#### 2: REMOVE GROUP ID

REMOVE GROUP ID: ENTER NO

ESC: GO BACK

KEY=

ESC: GO BACK

KEY=

### 2: SET MATRIX CONFIG

CURRENT MATRIX: NOT APPLICABLE

ESC: GO BACK

KEY=

### 3: SET SYNC DELAY

SELECT OUTPUT: ENTER NUMBER

1: SDL1=00 (00.00 Sec)

2: SDL2=00 (00.00 Sec)

3: SDL3=00 (00.00 Sec)

4: SDL4=00 (00.00 Sec)

5: SDL5=00 (00.00 Sec)

6: SDL6=00 (00.00 Sec)

7: SDL7=00 (00.00 Sec)

8: SDL8=00 (00.00 Sec)

ESC: GO BACK

KEY=

ESC: GO BACK

KEY=

### 3: STATUS

Equivalent to the [C] command.  
Return the card status.

### 4: HELP

This is equivalent to the [HELP] command.  
It displays a list of commands available for the **MT105-120/121** along with a brief description.

### ESC

Return to the parent menu.

## 7.4.5 MENU MODE EXAMPLES

All MENU MODE examples assume an **MT105-120** is installed in slot #4. Start by clicking the mouse in the Terminal window. Press ENTER and a list of available cards will be displayed.

**NOTE** When entering numeric values (not selecting menu items) the system may echo each character as it is typed. For example, entering a delay time of 03 may appear as 0033 on the screen. This is a property of the software being used to control the system.

### 1. Connect Input 2 to Output 2

Follow the keystrokes below to connect Input 2 to Output 2.

Enter	List available cards
4	Select MT105-120 in slot #4
1	Select CONTROL Menu
5	Select IN-OUT Select
2	Input 2
2	Output 2
	"ok" is displayed
S	New connections are displayed
ESC	Return to CONTROL Menu
ESC	Return to the MAIN Menu

### 2. Turn OFF Output 1

Starting from the main menu, turn OFF Output 1. Follow the keystrokes below.

1	Select CONTROL Menu
4	Select ON/OFF Menu. The Output ON/OFF statuses are displayed. The current setting is in "( )" next to the output number. In this case, Output 1 shows are ON.
1	Toggle Output 1 from ON to OFF. The card will respond with the feedback "OFF" and then "ok".
S	Redisplay the status of all outputs.
ESC	Return to the CONTROL Menu.
ESC	Return to the MAIN Menu

### 3. Set Sync Delay for Output 1 to 2 seconds.

Starting from the Main Menu, set the Sync Delay for Output 1 to 2 seconds. Follow the keystrokes below.

2	Select SETUP Menu
3	Select SET SYNC DELAY
1	Select SDL1 (Output 1)
8	Enter 8 (x250mS)=2 sec
ESC	Accept 2 sec value. Redisplay the SDL settings for all the outputs.
ESC	Return to SETUP Menu
ESC	Return to the MAIN Menu

### 4. Add Card 4 to Group 1

Starting from the Main Menu, make the **MT105-120/121** part of Group 1. Follow the keystrokes below.

2	Select SETUP Menu
1	Select SET GROUP ID
1	Select ASSIGN GROUP ID
1	Group 1. The card will feedback "G1=C4".
ESC	Return to Group Menu
ESC	Return to SETUP menu
ESC	Return to the MAIN Menu

## 5. Display Card Status

Starting from the Main Menu, follow the keystrokes below.

3            Displays card status

NOTE: The status will be displayed, followed by the Main Menu being redisplayed.

## TROUBLESHOOTING GUIDE 8

We have carefully tested and have found no problems in the supplied **MT105-120/121**; however, we would like to offer suggestions for the following:

### 8.1 CARD IS NOT RECOGNIZED

**Cause 1: The card is not recognized.**

*Solution:* Reset the card cage by sending the [RES] command, or turning the system power off and then on. Send the [C] command to see if there is communication with the card. If there is no feedback, see Cause 2.

**Cause 2: Card is not plugged in all the way.**

*Solution:* Push the card in all the way. Reset the system and send the [C] command. If the card is still not recognized, see Cause 3.

**Cause 3: Card cage slot has a problem.**

*Solution 1:* Test the card in other slots of the card cage. If the slot was damaged, the card may work in other slots. If other slots work and the card is recognized, the problem is the card cage slot. The card cage may require service. Call ALTINEX at (714) 990-2300. If the other slots do not work, see Solution 2.

*Solution 2:* Take any other known good card and verify that the slot used is good by seeing if the other card is recognized in that slot. If it is, then the original card may be the source of the problem. Call ALTINEX at (714) 990-2300.

### 8.2 NO DISPLAY

**Cause 1: The source has a problem.**

*Solution:* Check the source and make sure that there is a signal present and all source connections are correct. If the source is working and there is still no display, see Cause 2.

**Cause 2: The card output is not selected.**

*Solution:* Select the output. Accessible commands are in Section 7. If no display is present, see Cause 3.

**Cause 3: Cable connections are incorrect.**

*Solution:* Make sure that cables are properly connected and that the continuity and wiring are good. If there is still no display present, see Cause 4.

**Cause 4: The display has a problem.**

*Solution:* Make sure the display has power and is turned ON. If there is still no display, please call Altinex at (714) 990-2300.

## ALTINEX POLICY 9

### 9.1 LIMITED WARRANTY/RETURN POLICY

Please see the Altinex website at [www.altinex.com](http://www.altinex.com) for details on warranty and return policy.

### 9.2 CONTACT INFORMATION

**ALTINEX, INC**

592 Apollo Street

Brea, CA 92821 USA

**TEL:** 714 990-2300

**TOLL FREE:** 1-800-ALTINEX

**WEB:** [www.altinex.com](http://www.altinex.com)

**E-MAIL:** [solutions@altinex.com](mailto:solutions@altinex.com)